

USER'S OPERATING MANUAL FOR DIGITAL PROCESS INDICATOR WITH ALARM

(Models:- PI - 442 / PI - 772 / PI - 882 / PI - 992)



PI - 442
(72 X 72)



PI - 882
(48 X 96)



PI - 772
(72 X 72)



PI - 992
(96 X 96)

SPECIFICATIONS: -

1. **DISPLAY TYPE** : 4-Digit 7 segment LED (WHITE)

Model no.	PI-442	PI-882	PI-772	PI-992
Display height	0.36"	0.56"	0.56"	0.56"

2. INPUT

Sensor Input : TC-J,K,R,S,N,T,B & RTD (PT-100)
 Analog Input : 0 - 20mA, 4 - 20mA, 0 - 1VDC, 0 - 5VDC, 0 - 3.3VDC, 0 - 10VDC (Selectable)
 Range : -1999 to 9999
 Resolution : 0.001, 0.01, 0.1 & 1°C (Selectable)
 Digital Filter : 1 to 10 Selectable

3. OUTPUT

: 2 Nos. Relay / SSR (Need to specify)

a) Relay Output

Contact type : N/O, CM, N/C
 Contact Rating : 5A @ 250VAC or 30 VDC
 Life expectancy : > 5,00,000 operations
 Isolation : Inherent

b) SSR Drive Output

Drive Capacity : 12V @ 30mA.
 Isolation : Non-Isolated.

4. FUNCTION

: Both output work as Alarm

5. ENVIRONMENTAL

Operating Range : 0 ~50°C, 5~90% Rh
 Storage Humidity : 95% Rh (Non-condensing)

6. POWER SUPPLY

Supply Voltage : 90~270VAC, 50/60Hz.
 Consumption : 4W Maximum.

7. PHYSICAL

Housing : ABS Plastic.

Over all Dimensions:-

Dim Model	A	B	C	D	E	F	G	H
PI-442	48	48	8	75	43	44	44	9
PI-772	72	72	10	65	66	68	68	9
PI-992	96	96	10	45	89	92	92	9
PI-882	48	96	10	45	43	44	92	9

OVER ALL DIMENSIONS & PANEL CUT OUT (IN MM)

MODEL:-PI-442 / PI-772 / PI-992

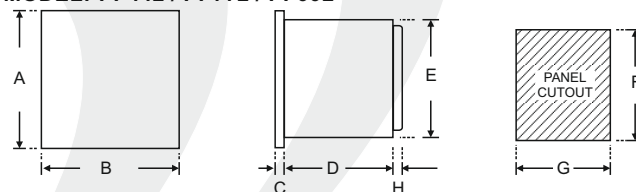

MODEL : PI-882

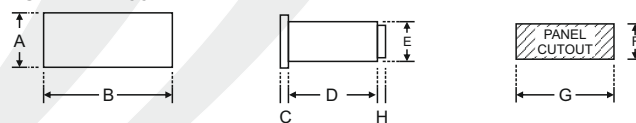

TERMINAL DIAGRAM:

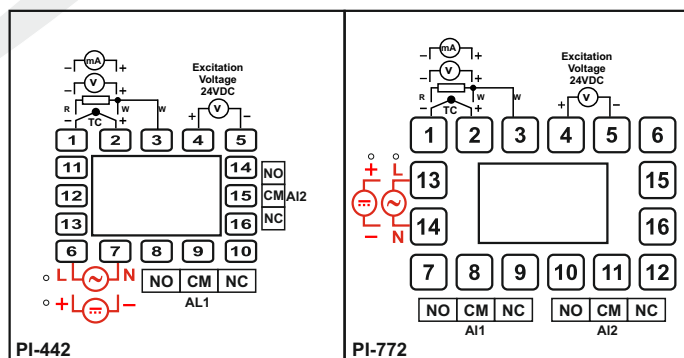

PI-442

PI-772

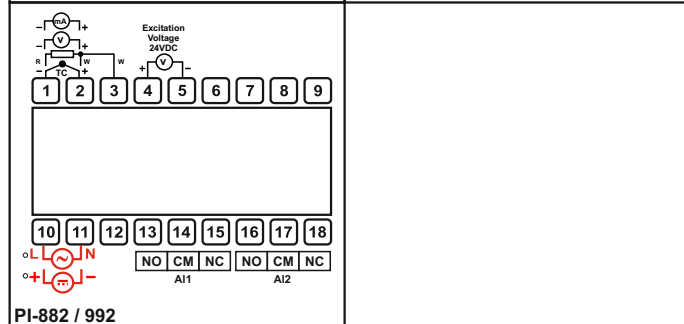

PI-882 / 992

Model no.	PI-442	PI-882	PI-772	PI-992
Weight (gms.)	130	200	200	240

PROGRAMMING



Press and Hold Shift Key Simultaneously for 3 Sec.

Press and Hold SET & UP Key Simultaneously for 3 Sec.

Press and Hold SET & DOWN Key Simultaneously for 3 Sec.

Press SET Key Once in Run Mode

Configuration			
Display	Default	Parameter Name	Range
LDCP	15	Lock Code	1 ~ 9999
INPT	J	Input Type	Ref Table 1
RESL	0	Resolution	Ref Table 1
LSPL	0	Lower Setpoint Limit	Refer Table 1
HSPL	400	Higher Setpoint Limit	Refer Table 1
AULO	0	Analog Input Low Value	Ref Table 2
A1HI	1200	Analog Input High Value	Ref Table 2
A1LG	d lr	Analog Input Logic	Direct, Reverse
OFSE	0	Process Value Offset	Refer Table 2
FLTR	6	Input Filter	0 ~ 10
ULOC	15	User Lock Code	15

Control List			
Display	Default	Parameter Name	Range
ALLP	15	Alarm Lock Code	1 ~ 9999
A1TY	LOV	Alarm 1 Type	Low, High, Band
A1LG	d lr	Alarm 1 Logic	Direct, Reverse
A1IH	n0	Alarm 1 Inhibit	Yes, No
A1AP	AUTO	Alarm 1 ACK.	Auto, Manual, Both
A1HY	2	Alarm 1 Hysterisis	Refer Table 2
A1SP	EnbL	Alarm 1 Setpoint	Enable, Disable
A2TY	LOV	Alarm 2 Type	Low, High, Band
A2LG	d lr	Alarm 2 Logic	Direct, Reverse
A2IH	n0	Alarm 2 Inhibit	Yes, No
A2AP	AUTO	Alarm 2 ACK.	Auto, Manual, Both
A2HY	02	Alarm 2 Hysterisis	Refer Table 2
A2SP	EnbL	Alarm 2 Set Point	Enable , Disable

User List			
Display	Default	Parameter Name	Range
A1SP	0	Alarm 1 Setpoint	LSPL ~ HSPL 2 ~ 99 °C
A1bd	0	Alarm 1 Band	Refer Table 2
A2SP	0	Alarm2 Setpoint	LSPL ~ HSPL 2 ~ 99 °C
A2bd	0	Alarm 2 Band	Refer Table 2

User Calibration			
Display	Default	Parameter Name	Range
UCLP	7	User Calibration Lock	1 ~ 9999
LCRAL	0	Low Calibration	0 ~ 9999
HCRAL	9999	High Calibration Ration	-1999 ~ 9999
FdEF	YES	Factory Default	Yes, No

Parameter will display according to below symbols	
	Input Type = Analog
	Alarm 1 Type = Band
	Alarm 2 Type = Band

Table 1 :- Range of Different Sensor Types.

Sensor Type	Range	Resolution
Fe-k(J) T/C	0 ~ 760°C	1°C
Cr-AL(K) T/C	-99 ~ 1300°C	1°C
(R) T/C	0 ~ 1700°C	1°C
(S) T/C	0 ~ 1700°C	1°C
TC - N	-99 ~ 1300°C	1°C
TC - T	-99 ~ 400°C	1°C
TC - B	0 ~ 1800°C	1°C
Pt-100 (RTD)	-100 ~ 450°C	1°C
Pt-100 (RTD 0.1)	-100.0 ~ 450.0°C	0.1°C
0 ~ 1 V	-1999 ~ 9999	0.000
0 ~ 3.3 V		00.00
0 ~ 5 V		000.0
0 ~ 10 V		0000
0 ~ 20 mA		(Selectable)
4 ~ 20 mA		

Table 2 :- Range as per Resolution.

Resolution	Analog Input Low Value	Analog Input High Value	Process Value Offset	Alarm 1 Band	Alarm 2 Band	ALARM 1 Hysterisis	ALARM 2 Hysterisis
0000	-1999 to 9999	-1999 to 9999	-25 to 25	-50 to 50	-50 to 50	1 to 25	1 to 25
000.0	-199.9 to 999.9	-199.9 to 999.9	-25.0 to 25.0	-50.0 to 50.0	-50.0 to 50.0	0.1 to 25.0	0.1 to 25.0
00.00	-19.99 to 99.99	-19.99 to 99.99	-15.00 to 25.00	-19.00 to 50.00	-19.00 to 50.00	0.01 to 25.00	0.01 to 25.00
0.000	-1.999 to 9.999	-1.999 to 9.999	-1.500 to 2.500	-1.900 to 5.000	-1.900 to 5.000	0.001 to 2.500	0.001 to 2.500

Error Message:-

Display Message	Selected Input	Descriptions
“OPEN”	TC-J,K,R,S,N,B or RTD	Open Circuit of Control Sensor
“HHHH”	TC-J,K,R,S,N,B or RTD	If input is above HSPL it will display “HHHH” message.
“HHHH”	0 ~ 20 / 4 ~ 20 / 0 ~ 10	If input is above range it will display “HHHH” message.
“LLLL”	TC - J,K,R,S,N,B or RTD	If input is below LSPL it will display “LLLL” message.
“LLLL”	0 ~ 20 / 0 ~ 10	If input is below ‘0’ it will display “LLLL” message.
“LLLL”	4 ~ 20	If input is below “3.8mA” and above “3.2mA” it will display “LLLL” message.
“L.BRK”	4 ~ 20	If input is less than “3.2mA” it will display “L.BRK” (Loop Break) message.
“C.E.R.R.”	Any Input Selected	The device is out of calibration and need to be sent to factory for re-calibration.



Mfgd by: Innovative Instruments & Controls LLP

Unit no 101- 105, Patel Industrial Estate, Building No.5, Near Range office, Gauraipada, Vasai East, Palghar, Maharashtra 401208.

Sales : +91-8591939916 / 17 / +91-8655832205

Support : +91-7208897610

E-mail : sales@itherm.co.in

Website : www.itherm.co.in

