

USER'S OPERATING MANUAL FOR PID DIGITAL TEMPERATURE CONTROLLER

(Models : AI 7441 / 7741 / 7941 / 7641 / 7841)



AI - 7441
(48 X 48)

AI - 7741
(72 X 72)

AI - 7941
(96 X 96)

AI - 7641
(96 X 48)

AI - 7841
(48 X 96)

SPECIFICATIONS : -

1. DISPLAY TYPE : 4- Digit 7 segment LED (Bright White)

Model no.	AI-7441	AI-7741	AI-7941	AI-7641	AI-7841
Display height	0.36"	0.56"	0.56"	0.36"	0.56"

STATUS LED : OP 1 : Main Control Output

2. INPUT

Sensor input : TC:J,K,R,S & RTD: Pt-100
Range : Refer below table.

Sensor Type	Range	Resolution	Accuracy
Fe-k(J) T/C	0 ~ 760°C	1 °C	± 1 °C
Cr-AL(K) T/C	-99 ~ 1300°C	1 °C	
(R) T/C	0 ~ 1700°C	1 °C	
(S) T/C	0 ~ 1700°C	1 °C	
TC - N	-99 ~ 1300°C	1 °C	
TC - T	-99 ~ 400°C	1 °C	
TC - B	0 ~ 1800°C	1 °C	
Pt-100(RTD)	-100 ~ 450°C	1 °C	± 0.3 °C
Pt-100(RTD 0.1)	-99.9 ~ 450.0°C	0.1 °C	

Sampling Time : 125 msec.
Resolution : 1°C/0.1°C(Only for RTD)
CJC for TC : Built in automatic
LWC for Pt-100 : Built in upto 18E max.
Digital Filter : 1 to 10 Sec.

3. RELAY OUTPUT

Contact type : N/O, CM, N/C
Contact Rating : 5A @ 250VAC or 30 VDC
Life expectancy : > 5,00,000 operations
Isolation : Inherent

4. SSR DRIVE OUTPUT

Drive Capacity : 12V @ 30mA.
Isolation : Non-Isolated.

5. FUNCTION

Output 1 : Main Control output
Control Action : ON-OFF/PID (Select)
Control Mode : Heat/Cool (Select)

6. ENVIRONMENTAL

Operating Range : 0 ~50°C, 5~90% Rh
Storage Humidity : 95% Rh (Non-condensing)

7. POWER SUPPLY

Supply Voltage : 90~270VAC, 50/60Hz.
Consumption : 4W Maximum.

8. PHYSICAL

Housing : ABS Plastic

Model no.	AI-7441	AI-7741	AI-7941	AI-7641	AI-7841
Weight (gms.)	130	200	240	200	200

SAFETY INSTRUCTION : -

This controller is meant for temperature control applications. It is important to read the manual prior to installing or commissioning of controller. All safety related instruction appearing in this manual must be followed to ensure safety of the operating personnel as well as the instrument.

GENERAL : -

- ❖ The controller must be configured correctly for intended operation. Incorrect configuration could result in damage to the equipment or the process under control or it may lead personnel injury.
- ❖ The controller is generally part of control panel and in such a case the terminals should not remain accessible to the user after installation.

MECHANICAL : -

- ❖ The Controller in its installed state must not come in close proximity to any corrosive/combustible gases, caustic vapors, oils, steam or any other process by-products.
- ❖ The Controller in its installed state should not be exposed to carbon dust, salt air, direct sunlight or radiant heat.
- ❖ Ambient temperature and relative humidity surrounding the controller must not exceed the maximum specified limit for proper operation of the controller.
- ❖ The controller in its installed state must be protected against excessive electrostatic or electromagnetic interferences. Ventilation slits provided on the chassis of the instrument are meant for thermal dissipation hence should not be obstructed in the panel.

ELECTRICAL : -

- ❖ The controller must be wired as per wiring diagram & it must comply with local electrical regulation.
- ❖ Care must be taken not to connect AC supplies to low voltage sensor input.
- ❖ Circuit breaker or mains s/w with fuse (275V/1A) must be installed between power supply and supply terminals to protect the controller from any possible damage due to high voltage surges of extended duration.
- ❖ Circuit breaker and appropriate fuses must be used for driving high voltage loads to protect the controller from any possible damage due to short circuit on loads.
- ❖ To minimize pickup of electrical noise, the wiring for low voltage DC and sensor input must be routed away from high current power cables. Where it is impractical to do this, use shielded ground at both ends.
- ❖ The controller should not be wired to a 3-Phase supply with unearthed star connection. Under fault condition such supply could rise above 264 VAC which will damage the controller.
- ❖ The Electrical noise generated by switching inductive loads might create momentary Fluctuation in display, alarm latch up, data loss or permanent damage to the instrument. To reduce this use snubber circuit across the load.
- ❖ It is essential to install a over Temp. Protection device to avoid any failure of heating system. Apart from spoiling the product, this could damage the process being controlled.

PROGRAMMING



Press and Hold SET & UP Key Simultaneously for 3 Sec.

Press and Hold SET & DOWN Key Simultaneously for 3 Sec.

Press & Hold Shift Key for 3 Sec. in Run Mode

Press SET Key Once in Run Mode

Configuration			
Display	Default	Parameter Name	Range
LOCK	15	Lock Code	1 ~ 9999
InPt	J	Input Type	J, K, R, S, N, T, B RTD, RTD.1
LSPL	0	Lower Set Point Limit	Ref Table 1
HSPL	400	Higher Set Point Limit	Ref Table 1
OFFSE	0	Process Value Offset	-25 ~ 25 -25.0 ~ 25.0 (RTD.1)
FLtr	6	Input Filter	1 ~ 10
modE	PId	Control Mode	PID, On-Off
OPIL	HEAt	Control Logic	Heat, Cool
OPtY	rLY	Output Type	Relay, SSR
OCp	dSbL	Overshoot Control Point	0 ~ 100
tunE	EnbL	Auto Tune	Enable, Disable
SP	EnbL	Setpoint 1	Enable, Disable
ULOC	15	User Lock Code	1 ~ 9999

Control List			
Display	Default	Parameter Name	Range
LOCK	15	Lock Code	1 ~ 9999
Pb	5.0	Proportional Band	0.5 ~ 99.9 °C
Int	240	Integral Time	0 ~ 3600 Sec.
dt	60	Derivative Time	0 ~ 300 Sec.
CYCL	160	Cycle Time	1.0 ~ 100.0 Sec.
OUTL	100.0	Output Power Limit	0.0 ~ 100.0 %
EOFS	100	Tune Offset	50.0 ~ 100.0 %
HY1	2	Control Hysteresis	1 ~ 100 0.1 ~ 100.0 (RTD.1)
dLY1	0	Delay 1	0 ~ 500 Sec.
OP.OF	dSbL	Output Off	0 ~ 10

User List			
Display	Default	Parameter Name	Range
SP1	0	Control Setpoint	LSPL ~ HSPL

Auto Tuning Mode			
Display	Default	Parameter Name	Range
tUnE	n0	Auto Tuning Mode	Yes, No

Parameter will display according to below symbols	
⚙	Control Mode = PID
■	Control Mode = ON-OFF

OVER ALL DIMENSIONS & PANEL CUT OUT (IN MM)

MODEL:-AI-7441/7741/7941

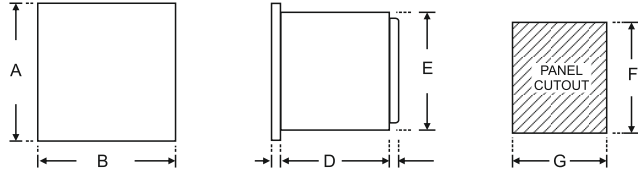

MODEL : AI -7641

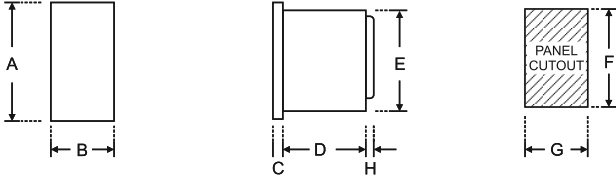

MODEL : AI -7841

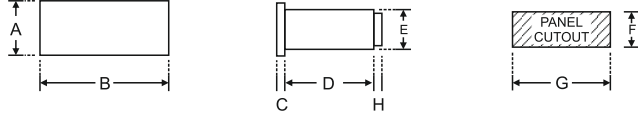

TABLE : 1

Dim Model	A	B	C	D	E	F	G	H
AI-7441	48	48	8	75	43	44	44	9
AI-7741	72	72	10	65	66	68	68	9
AI-7941	96	96	10	45	89	92	92	9
AI-7641	96	48	10	45	89	92	44	9
AI-7841	48	96	10	45	43	44	92	9

INSTALLATION GUIDELINES

1. Prepare the cut-out with proper dimension as shown in figure.
2. Remove clamp from controller
3. Push the controller through panel cut-out and secure the controller in its place by tightening the side clamp.

ELECTRICAL INSTALLATION

The electrical connection diagram is shown on the controller enclosure as below.

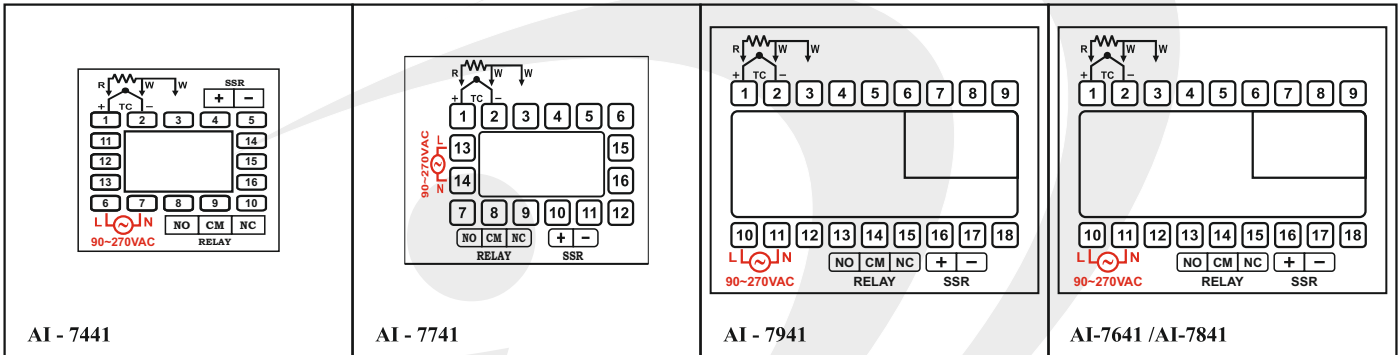

FRONT PANEL LAYOUT

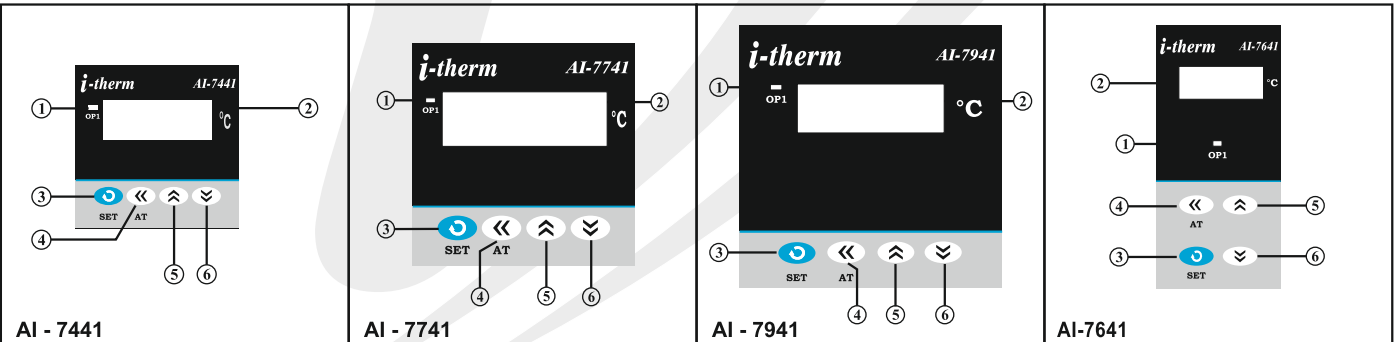

FRONT PANEL LAYOUT DESCRIPTION :

Sr.	NAME	FUNCTION
1	OP1 LED	Glows when OP1 is ON & flashes when delay time (dly1) is in operation(if selected mode is ON-OFF)
2	UPPER DISPLAY	It will display (1)Measured value of selected input or Error messages. (2) SP value in run mode. Parameters Values/code in program mode
3	SET KEY	(1) For SP programming. (2) To access Control mode. (3) To access Configuration mode along with UP key. (4) To scroll the parameter & to store its value.
4	SHIFT KEY	(1) To increase/alter parameter value in program mode with Up / Dn Key. (2) Press for 3Sec in Programming this will help to go back to previous parameter.
5	UP KEY	(1) To increase/alter parameter value in program mode. (2) To Enter in configuration mode (with SET key) . (3) To acknowledge Alarm. (4) To enter in tune mode (with DOWN Key).
6	DOWN KEY	(1) To decrease / alter parameter value in program mode. (2) To enter in tune mode (with UP Key).



Mfgd by: Innovative Instruments & Controls LLP

Unit no 101- 105, Patel Industrial Estate, Building No.5, Near Range office, Gaurapada, Vasai East, Palghar, Maharashtra 401208.

Sales : +91-8591939916 / 17 / +91-8655832205

Support : +91-7208897610

E-mail : sales@itherm.co.in

Website : www.itherm.co.in

